



enLighten

Commercial/Office Luminaire

NEW

Backlit design with significantly improved efficacy

Skyline

Superior construction, high performing, low glare LED panel

The Skyline is a low glare, backlit LED panel that provides a quality solution for office or school environments. Occupant comfort is ensured through a microprismatic diffuser that distributes the light evenly and eliminates glare.

The Skyline offers superior efficacy that makes it perfect for retrofit environments where government incentives apply.

The panel is professionally finished with a seamless, screwless frame that delivers an elegant and perfectly flat appearance.

Suitable for recessed or surface mounted applications.

OPTIONS AND BENEFITS

- **Easy installation** with 1.5m flex & plug
- **Low glare, UGR<19** design to maximise comfort
- **Flicker free driver** performance to reduce eye strain
- **High luminaire efficacy** of up to 170lm/W
- **IP54** - front side for extra protection
- **Seamless frame** for enhanced appearance & rigidity
- **Suitable for standard ceiling grid sizes**
- **Mounting options available** - Recessed & surface mounted kits
- **Air Return frames available**
- **Control Options** - DALI-2 and Casambi
- **Tunable white option**
- **Lower power** - 15W for single tube fluoro replacements
- **5 year warranty**



(Non-dimming & CRI80 models only)

APPLICATIONS



CLASSROOMS



DAYCARE



GOVERNMENT BUILDINGS



LARGE RETAIL



LECTURE HALLS



LIBRARIES



MEETING ROOMS



OFFICE AREAS

FEATURES



CEILING RECESSED



FLICKER FREE



LOW GLARE



SAFETY COMPLIANCE



SURFACE MOUNT



TUNABLE WHITE



5 YEAR WARRANTY

SKYLINE PRODUCT RANGE

Model #	Driver Model #	CRI	Rated Power (W)	Lumens (lm)	Size (mm)	Weight (kg)
SKY2-6030-8yy	SKY2-15-DRI	80	15	2200	595 x 295	1.0
SKY2-6060-8yy				2470	595 x 595	1.9
SKY2-1230-8yy					1195 x 295	2.0
SKY2-6060-8yy	SKY2-19-DRI		19	3170	595 x 595	1.9
SKY2-1230-8yy					1195 x 295	2.0
SKY2-6060-8yy	SKY2-40-DRI				40	6200
SKY2-1230-8yy		1195 x 295	2.0			
SKY2-6060-9yy	SKY2-26-DRI	90	26	3170		
SKY2-1230-9yy					1195 x 295	2.0

yy stands for CCT. Use 30 for 3000K, 40 for 4000K, 50 for 5000K
To complete your installation, please remember to order both the Skyline panel and the compatible driver.

*Contact enLighten for model numbers for DALI-2 and Casambi lighting options.

RECESSED PLASTER FRAMES

Model Code	Fits Skyline Model	Cut-Out Size (mm)	Dimensions (mm)
R-001	SKY2-1230	1210 x 310	1230 x 330 x 40
R-002	SKY2-6060	610 x 610	630 x 630 x 40
R-003	SKY2-6030	610 x 310	630 x 330 x 40

SURFACE MOUNT FRAMES

Model Code	Fits Skyline Model	Dimensions (mm)
SM2-001	SKY2-1230	300 x 1200 x 63
SM2-002	SKY2-6060	600 x 600 x 63
SM2-003	SKY2-6030	300 x 600 x 63

AIR RETURN FRAMES

Model Code	Fits Skyline Model	Dimensions (mm)
ARF-001	SKY2-1230	1200 x 450 x 40
ARF-002		1275 x 400 x 40
ARF-003		1350 x 450 x 40
ARF-004		1275 x 450 x 40
ARF-006	SKY2-6030	595 x 395 x 40

TECHNICAL INFORMATION

Optical	
Lumen output	2420 - 6200 lumens
CRI	Ra>80 (standard), Ra>90 (optional)
CCT	4000K standard with 3000K, 5000K optional
Luminaire efficacy	Up to 170lm/W
Glare rating (UGR)	UGR < 19
Electrical	
Power consumption	15W-40W
Operating frequency	50Hz
Operating voltage range	220 - 240V AC
Power factor	>0.95 / 240V AC
Environmental	
IP rating	IP54(front)/IP40(back)
Ambient temperature range	-20°C to 40°C
Material Composition (body)	White powder-coated aluminium
Expected Lifespan	>120,000 hours @ 70% lumen maintenance
Controls - Optional	
Dimming	DALI-2 Casambi Koolmesh
Warranty*	
	5 years

Data subject to change without notice
* Refer to warranty policy

PHOTOMETRICS

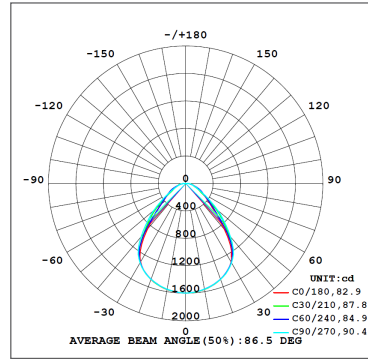
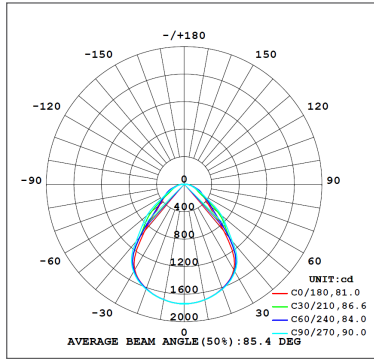

Model: SKY2-6060-8yy

Model: SKY2-1230-8yy

FITTING DIMENSIONS

SKY2-1230-8yy

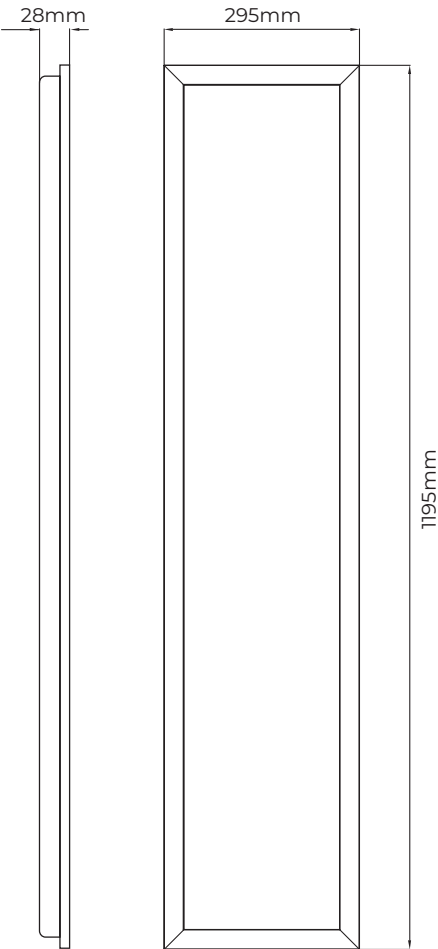

SKY2-6060-8yy

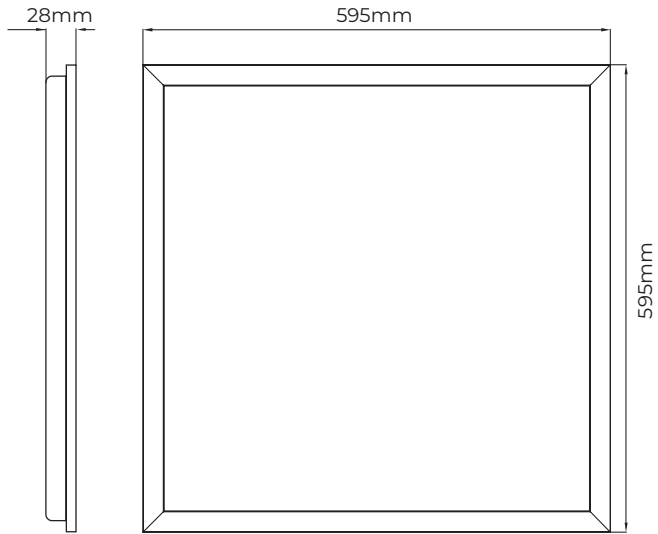

SKY2-6030-8yy

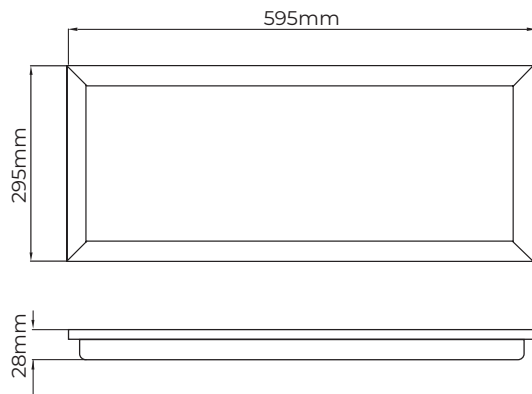



AIR RETURN FRAME DIMENSIONS

ARF-003

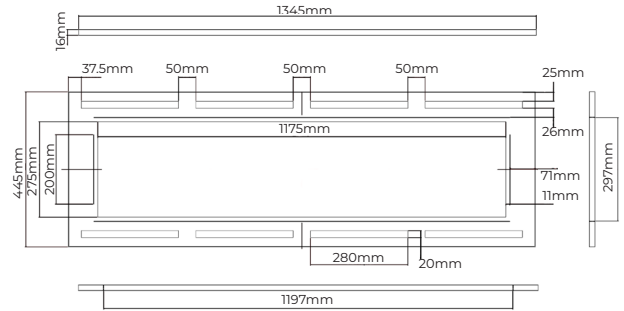

ARF-004

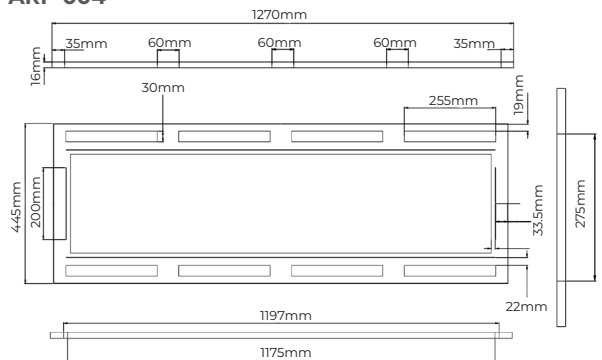

ARF-006

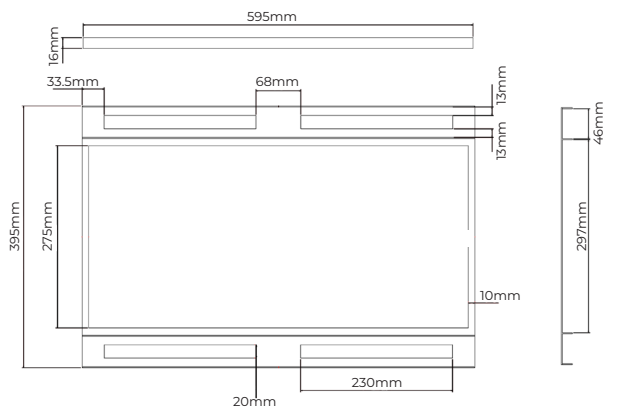

ARF-001

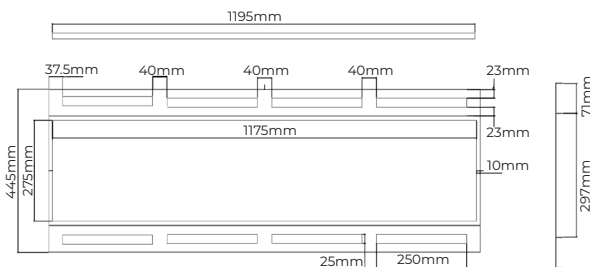

ARF-002

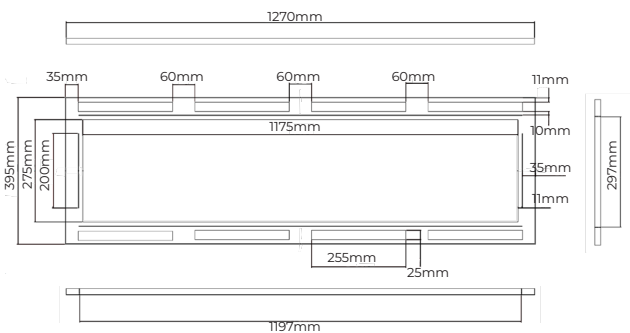

COMPLIANCE

The Skyline LED panel meets or exceeds all relevant standards and regulatory requirements.

For a full compliance and testing list visit www.enlighten.com.au. IES files, warranty, installation and product guides are also available for download.

Sold nationally through major electrical wholesalers.

